

## 12 Ton Clevis Bracket

### Bracket Capacity

- 1,500 lbs. Max. Vertical Load
- 24,000 lbs. Max. Gross Trailer Weight.
- 3 3/8" x 1 3/4" Bolt Pattern

### IMPORTANT SAFETY INFORMATION

Maintain adequate vertical down (tongue) load to have control of the trailer (generally 10%), but do not exceed the above rated capacities

Other steps and inspections are also required. Consult OSHA and D.O.T. regulations and American Trucking Association for complete coupling and uncoupling procedures.

### GENERAL INFORMATION

1. Do not modify or add to the product.
2. Wear safety glasses during installation, removal and servicing.
3. Never strike any part of the item with a steel hammer.
4. Do not weld on this product.
5. It is the user's responsibility to ensure that the receiver mount is capable of 2,500 lb. Vertical load and 24,000 lb. gross trailer weight.

### TOWING APPLICATIONS

Trailers and equipment designed for on-road towing within the stated capacities. For off-road applications, reduce the capacities listed above by 25%, and use in conjunction with a swivel-type drawbar. This pintle hook/ball hitch is well suited for use in the utility and construction industries.

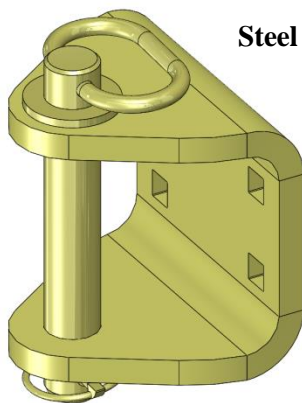

Steel – Zinc Plated

### MOUNTING

1. Use a secure mounting structure of sufficient strength to support the rated capacity of the Hitch in accordance with SAE J 849B.
2. Use the hole pattern described on the reverse.
3. Use (4) 1/2" (.50") grade 8 fasteners (per SAE J429), torque plated bolt to 65 ft-lbs., torque plain bolt to 100 ft-lbs.

\*Bolts can be mounted either direction.

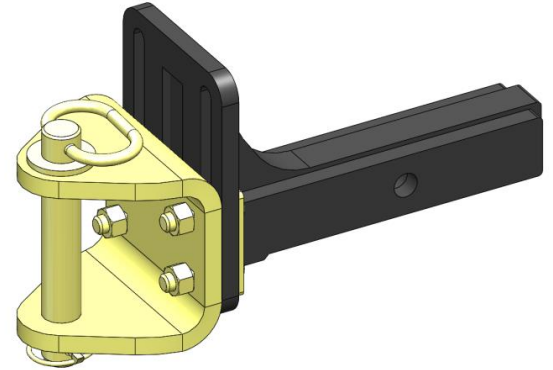

12 Ton adjustable slide mount bracket #ASMB12TBA (Sold Separately)

### CLEVIS BRACKET

1. Clevis bracket can be mounted directly on the vehicle or mounted on our 12 Ton adjustable slide mount and slide into a receiver.

### OPERATION AND MAINTENANCE

For proper performance, the following should be performed every 10,000 miles or 6 months, whichever comes first.

1. Inspect for proper operation.
2. Inspect, in particular, the coupling area. Replace when wear exceeds 1/8" (.125") from original surface profile.
3. Inspect for worn, damaged and missing parts. Replace as required.
4. Check torque specification of ball after the first 200 miles of towing and every 400 miles after that.

[WWW.POWERPIN.CA](http://WWW.POWERPIN.CA)

### Warranty

This product is to be free from defects in material and workmanship for a period of one year from date of shipment. Parts must be properly installed. Any product which has been altered, Modified, misuse, or lack of maintenance will not be considered under warranty. Authorization from Power Pin Inc. must be obtained before returning any part. The sole responsibility of Power Pin Inc. under this warranty is limited to repairing or replacing any parts which are returned, prepaid, and are found to be defective by Power Pin Inc. No charges for transportation or labor performed on this product will be allowed under this warranty.